

MAKE SURE YOUR FIREARM IS UNLOADED & SAFETY IS ENGAGED BEFORE STARTING!

HEATSHIELD INSTALLATION INSTRUCTIONS

GUNS WITH LARGE BARREL DIAMETERS:

- 1) **Single Shot Shotgun**—Remove forend (Go to #7)
- 2) **Pump Shotgun**—To remove barrel, pump forend halfway to rear, remove magazine cap, and pull barrel forward and off the gun. (Go to #7)

GUNS WITH SMALL BARREL DIAMETERS:

- 1) Measure diameter of barrel at receiver end, and purchase a wooden dowel similar to this diameter (Dowel must be longer than 6") (Fig. 4)
- 2) Place a 6" wooden dowel inside heatshield at the receiver end (Fig. 5)
- 3) Wrap protective cloth over edge of heatshield and use pliers to slowly bend edge along receiver end to custom fit shield to width of gun receiver. (Fig. 5) (Slide shield over barrel to check fit-up of shield to receiver often) (Go to #7)

ALWAYS USE PROTECTIVE CLOTH TO PREVENT SCRATCHES.

CAUTION: DO NOT OVER TIGHTEN ANY SCREWS.

GUNS WITH SCOPE MOUNT:

- 1) Remove Forend, Scope Mount and Ghost Ring Sights from heatshield.
- 2) Install heatshield onto gun and bend tabs for temporary fit-up. (Fig. 3 & 5)
- 3) Bend edges and place forend onto gun for clearance check only. (Fig. 5)
- 4) Remove heatshield and forend, use cutout template below for specific gun, trace profile, leaving 1/8" of heatshield material at receiver end (Fig. 6)
- 5) Use Dremel tool to cut profile from heatshield (Fig. 6)

(Caution: LEAVE 1/8" OF HEATSHIELD MATERIAL AT RECEIVER END)

- 6) Use Dremel tool to remove 1/16" deep X 1/8" long material from bottom radius of scope mount rail at receiver end. (Fig. 7)
- 7) Slide shield over barrel, position toward rear, and bend tabs to clamp on barrel (Install scope mount rail if required). (Fig. 3 & 5)
- 8) For Small Barrel Guns: Place rubber spacer (i.e., Rubber Hose) over barrel and under front of heatshield.
- 9) For Pump Shotguns: Reinstall the barrel and magazine cap.
- 10) Using pliers with protective cloth, squeeze front tabs to place two screws through holes. (Fig. 1 & 2)
- 11) Heatshield may require additional custom fitting for pump shotguns—slide forend back and forth to check clearance between forend and heatshield.

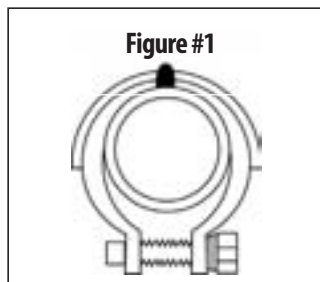

Figure #1

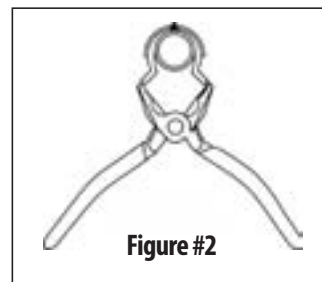

Figure #2

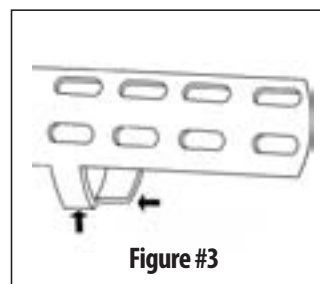

Figure #3

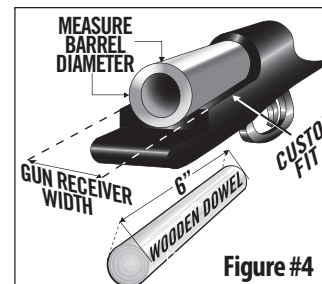

Figure #4

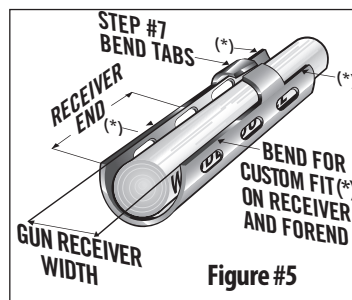

Figure #5

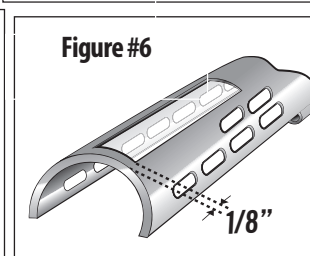

Figure #6

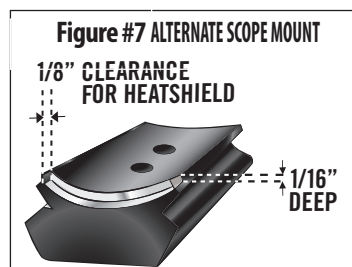

Figure #7 ALTERNATE SCOPE MOUNT

Adobe Acrobat Reader default MUST be changed to print template accurately and actual size.

PRINTING INSTRUCTIONS FOR TEMPLATE

1. File
2. Print
3. Page Scaling : NONE
4. PRINT

END OF H&R/NEF

END OF ROSSI

WEAVER RAIL CUTOUT TEMPLATES

