

Fits: Mossberg 500*/535/590/835, Remington 870, Winchester 1200/1300

Includes: Pistol Grip Forend, Rear Pistol Grip, Heatshield & Tactical Flashlight Mount

NOTE: SYNTHETIC FORENDS ON NEW MOSSBERG MODEL 500A CANNOT BE REPLACED BECAUSE ACTION BARS ARE ATTACHED TO THE FOREND.

FLASHLIGHT MOUNT Part #STM1200 (Item 1)

MAKE SURE YOUR SHOTGUN IS UNLOADED BEFORE STARTING!

- STEP 1** Place light mount in the bottom of pistol grip. Drill a 3/32" hole through one side of the grip and all the way through the light mount to a maximum depth of one inch. The hole should be 3/8" from the bottom and in the center of the textured grip area. Counter sink the screw head for flush mounting. This hole may be drilled from either side, **however it is best to place screw head opposite of the palm of your hand.**
- STEP 2** Install the supplied mounting screw and tighten.
- STEP 3** The light mount fits any 1" diameter flashlight and includes an adapter to fit small AA mini flashlights. Slide flashlight into the mounting tube and tighten the two screws.
(Go to Forend Pistol Grip Installation on back)

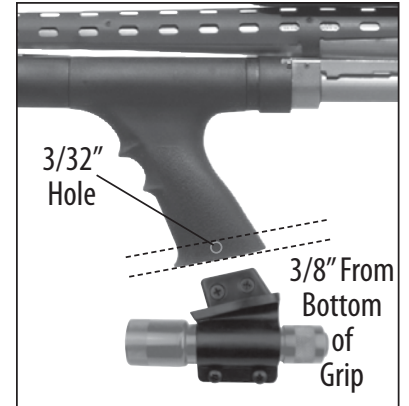

REAR PISTOL GRIP Part #SRG0200 (Item 3)

FITS: Mossberg 500*/590/835, Remington 870, Winchester 1200/1300, Maverick 88 and Norinco 98 Shotguns

TO INSTALL REAR PISTOL GRIP

MAKE SURE YOUR SHOTGUN IS UNLOADED BEFORE STARTING!

FOR 20GA INSTRUCTIONS VISIT WWW.ATGUNSTOCKS.COM

- STEP 1** Remove the existing recoil pad from your shotgun stock by unscrewing the 2 Phillips head screws in the rear of the pad.
- STEP 2** Use a long flat blade screwdriver to remove the stock bolt from the inside of the opening in the rear of the stock.
- STEP 3** Select the adapter for your shotgun. (None required for Mossberg).
- STEP 4** Select the mounting bolt supplied for your shotgun.
- STEP 5** Place the bolt, with supplied washer, through the back of the grip and adapter (if used) and secure to the shotgun receiver by tightening bolt.
- STEP 6** Place pistol grip end cover at the rear of grip and press in place.

CAUTION: Do not overtighten any screws.

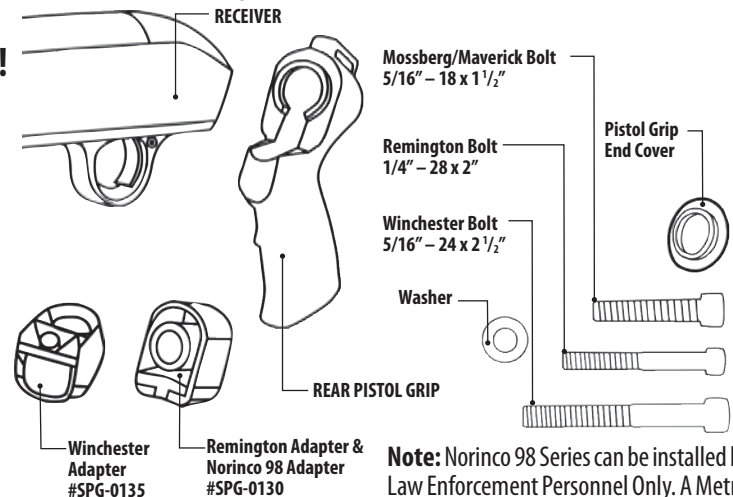

HEATSHIELD Part #SHS1300 (Item 4)

Easily adapts to most 12 Gauge shotgun barrels.

MAKE SURE YOUR SHOTGUN IS UNLOADED BEFORE STARTING!

- STEP 1** Remove barrel from receiver, see owners manual for instruction.
- STEP 2** Once barrel is removed, widen the front clamp 1/8 inch and slip Heatshield over the front barrel toward the rear.
- STEP 3** Reinstall the barrel.
- STEP 4** Bend rear tabs to fit snugly around the barrel. Tighten front clamp around barrel and install screws, tighten securely. (Fig. A&B)
- STEP 5** Carefully, slide the forend back and forth. Check for interference between slide and Heatshield. Correct any interference with file where shown. (Fig. C)

NOTE: SYNTHETIC FORENDS ON NEW MOSSBERG MODEL 500A CANNOT BE REPLACED BECAUSE ACTION BARS ARE ATTACHED TO THE FOREND.

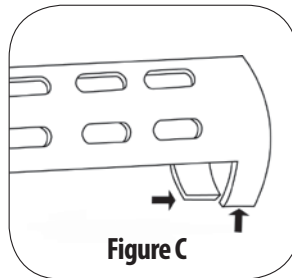
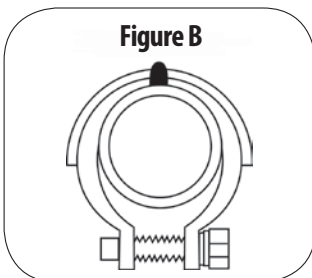
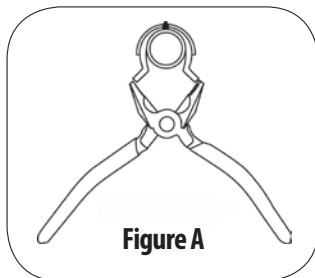

Fits: Mossberg 500*/535/590/835, Remington 870, Winchester 1200/1300

Includes: Pistol Grip Forend, Rear Pistol Grip, Heatshield & Tactical Flashlight Mount

Thank you for purchasing one of Advanced Technology Inc.'s SHOTFORCE COMPONENTS!
Please fill out the enclosed Unconditional Lifetime Warranty card and mail it within 30 days of purchase.

****NOTE: SYNTHETIC FORENDS ON NEW MOSSBERG MODEL 500A CANNOT BE REPLACED BECAUSE ACTION BARS ARE ATTACHED TO THE FOREND.****

FOREND ASSEMBLY INSTRUCTIONS (Item 2)

(Remove Plastic Bridge)

FRONT ADAPTERS

Part Numbers Marked
Inside Adapters
Mossberg 500 Long = MF1
Mossberg 500 Short = MF2
Remington 870 = RF (Norinco)
Winchester 1200/1300 = VF

(Remove Plastic Bridge)

REAR ADAPTERS

Part Numbers Marked
Inside Adapters
Mossberg 500/590/835 = MR
Remington 870 = RR (Norinco)
Winchester 1200/1300 = WR

- Remove ring nut from front of tube.
- Remove old forend by pulling it forward off the tube.
- Select front and rear adapters for your shotgun.
- Assemble as shown.
- Place ring nut on forend tube and tighten.

**FOR 20GA INSTRUCTIONS VISIT
WWW.ATIGUNSTOCKS.COM**

- Step 1** Cycle action once to make sure hammer is cocked and engage safety.
- Step 2** Depress slide release and pull forend approximately halfway back, loosen magazine cap and remove barrel.
- Step 3** (Mossberg) Remove trigger group retaining pin by tapping it out with a blunt pin no greater than 3/16" in diameter.
(Winchester) Remove trigger group retaining pin by tapping it out with a blunt pin no greater than 1/4" in diameter.
(Remington and Norinco) Depress and hold left shell stop (see figure #2).
- Step 4** (Mossberg) Place shotgun upside down and pull out trigger group by lifting up at the rear. (see figure #5)
(Winchester) Place shotgun upside down and remove retainer and trigger group pin. (see figure #8)
- Step 5** (Mossberg) Remove shell stop and shell interrupter from receiver.
(Winchester) Turn shotgun back upright and pull forend forward and off magazine tube. Remove bolt from action bars.
(Remington) Slide forend forward off magazine tube. NOTE: The bolt and slide block will also be removed (see figure #3).
- Step 6** (Mossberg) Align bolt slide with cut out in receiver by moving forend and action bars back and forth. Remove bolt slide upward (figure #7). Pull forend and action bars forward & remove from magazine tube.
- Step 7** (All Models) Assemble forend as shown above in figure #1.

- Step 8** (Mossberg) To reassemble, slide forend back on magazine tube and align action bars with the openings in the receiver.
(Remington) Slide forend back on magazine tube and replace bolt and slide block. (see Figure #3) Place action bars into receiver and pull rearward until it stops.
(Winchester) Place forend back on magazine tube and replace bolt in the action bar slots (See figure #9).
- Step 9** (Mossberg) Align the slots on the action bars with the slots on the bolt slide and replace bolt slide (figure #7).
(Remington) Press right shell stop (figure #4). The forend with the bolt will slide further rearward and stop again. Press the left shell stop (see figure #2) and the forend will travel fully to the rear.
(Winchester) Align action bars with openings in the receiver and pull the forend rearward.
- Step 10** (Mossberg) Replace both the shell interrupter and shell stop (figure #6).
(Remington) Slide the forend forward approximately half way and replace barrel and magazine cap.
- Step 11** (Mossberg) Replace trigger group and pin (see figure #5).
(Winchester) Turn shotgun upside down and replace trigger group and retain pin (see figure #8).

Go to Item #3 on reverse

